

姿図

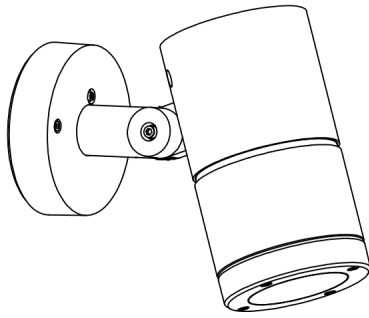

品番	LLS-7103YUM
光源	LED 38W 3000K
定格光束	2910.0 lm
1/2照度角	18°
ビーム角	18°

器具効率	100.0 %
上方光束	0.0 %
下方光束	100.0 %
器具間隔 最大限 (取付高さH)	A 0.32 H
	B 0.33 H
保守率	良 0.69
	中 0.67
	否 0.63

反射率 (%)	天井	80			70			50			30			0
	壁	50	30	10	50	30	10	50	30	10	50	30	10	0
床	20			20			20			20			0	
室指数	照 明 率 (× 0.01)													
0.6	84	80	77	84	79	76	83	79	76	82	78	76	75	
0.8	90	85	82	89	85	81	88	84	81	86	83	80	79	
1	95	90	87	94	90	87	92	89	86	91	88	85	83	
1.25	99	95	92	98	94	91	96	93	90	94	91	89	87	
1.5	102	98	95	101	97	95	99	96	93	97	94	92	89	
2	107	104	101	106	103	100	103	100	98	100	98	97	94	
2.5	111	108	106	109	106	104	106	104	102	103	101	100	97	
3	113	111	109	111	109	107	108	106	105	105	104	102	99	
4	115	114	112	113	112	111	110	109	108	106	105	105	100	
5	117	116	114	115	114	113	111	110	109	107	107	106	101	

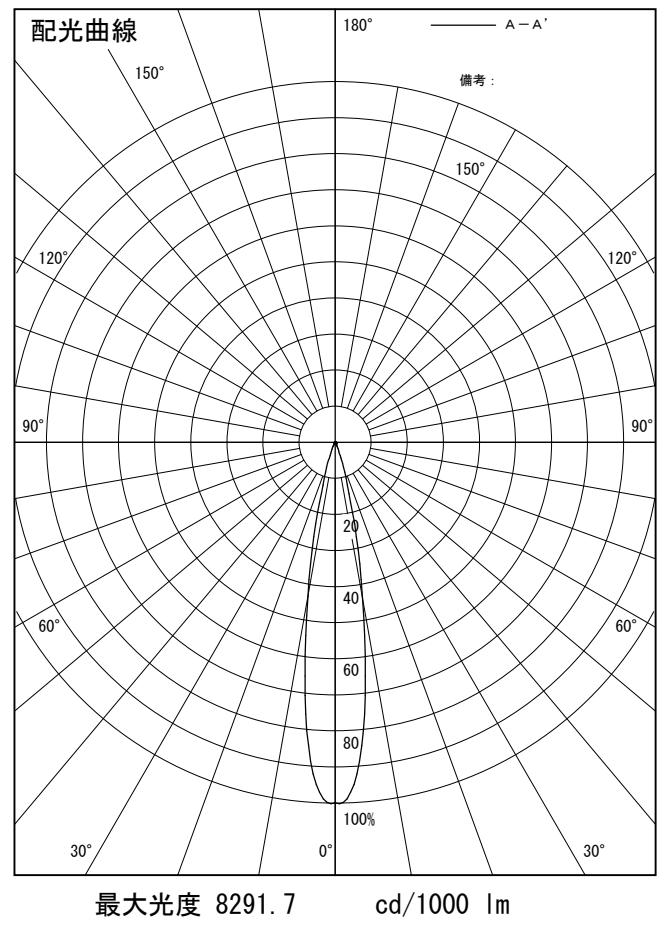
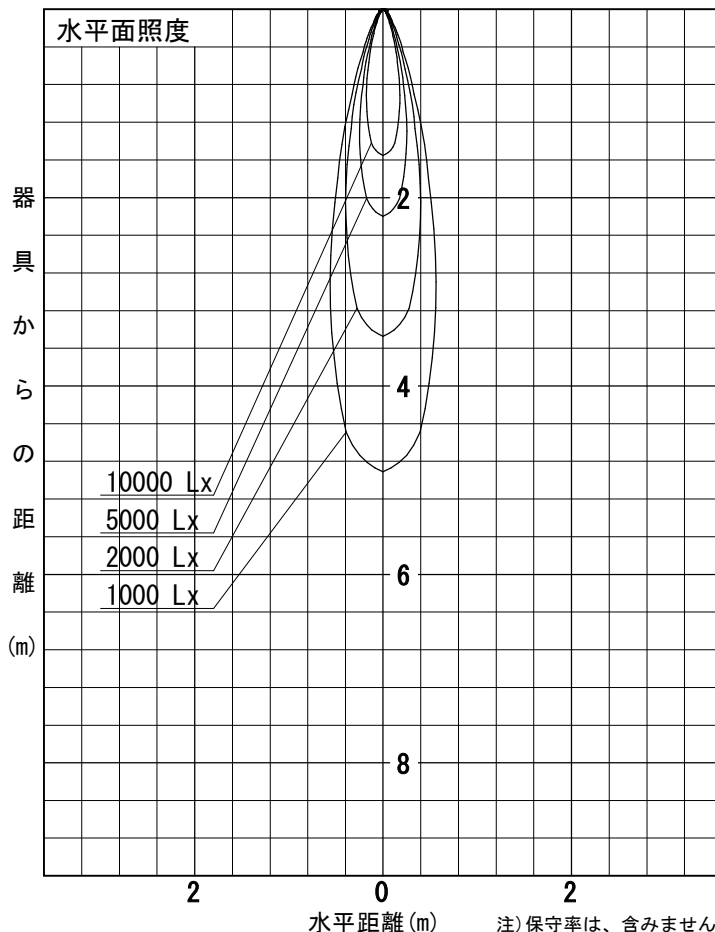

姿図

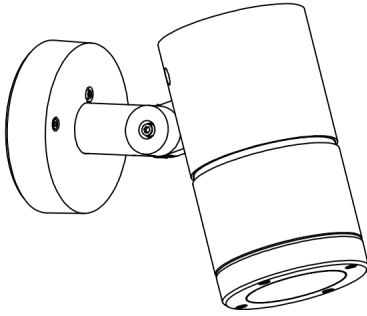

品番	LLS-7103YUM+LZA-92954
光源	LED 38W 3000K
定格光束	2270.0 lm
1/2照度角	17°
ビーム角	16°

器具効率	100.0 %
上方光束	0.0 %
下方光束	100.0 %
器具間隔 最大限 (取付高さH)	A 0.30 H
	B 0.30 H
保守率	良 0.69
	中 0.67
	否 0.63

反射率 (%)	天井	80			70			50			30			0
	壁	50	30	10	50	30	10	50	30	10	50	30	10	0
床	20			20			20			20			0	
室指数	照 明 率 (× 0.01)													
0.6	84	79	76	83	79	76	82	79	76	82	78	76	74	
0.8	89	85	81	89	84	81	87	84	81	86	83	80	79	
1	95	90	87	94	90	87	92	89	86	91	88	85	83	
1.25	99	95	92	98	94	91	96	93	90	94	91	89	87	
1.5	102	98	95	101	97	94	99	96	93	96	94	92	89	
2	107	104	101	106	103	100	103	100	98	100	98	97	94	
2.5	111	108	105	109	106	104	106	104	102	103	101	100	96	
3	113	111	109	111	109	107	108	106	105	105	103	102	99	
4	115	114	112	113	112	111	110	108	107	106	105	105	100	
5	117	116	114	115	114	113	111	110	109	107	107	106	101	

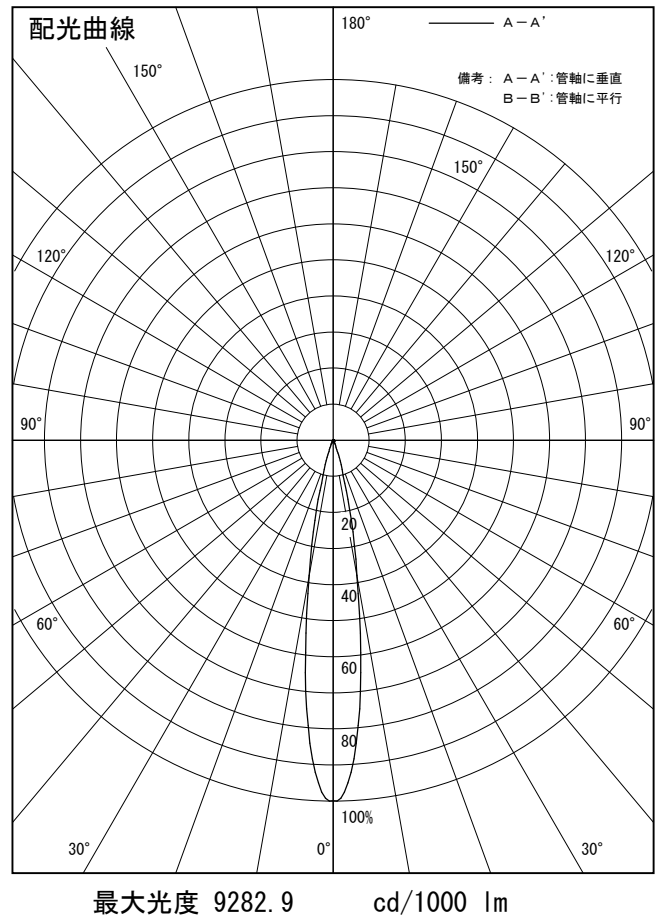
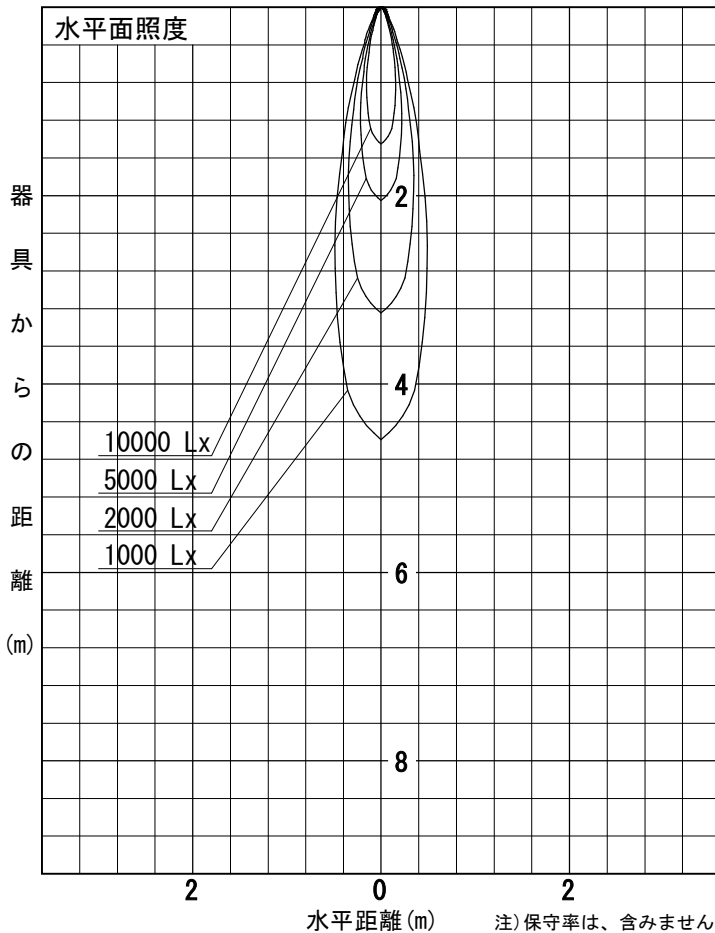

姿図

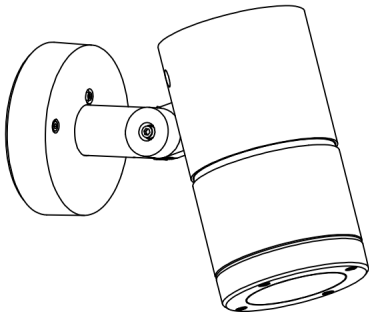

品番	LLS-7103YUM+LZA-92558
光源	LED 38W 3000K
定格光束	1780.0 lm
1/2照度角	36°
ビーム角	40°

器具効率	100.0 %
上方光束	0.0 %
下方光束	100.0 %
器具間隔 最大限 (取付高さH)	A 0.65 H
	B 0.64 H
保守率	良 0.69
	中 0.67
	否 0.63

反射率 (%)	天井	80			70			50			30			0
	壁	50	30	10	50	30	10	50	30	10	50	30	10	0
床	20			20			20			20			0	
室指数	照 明 率 (× 0.01)													
0.6	82	77	74	81	77	74	80	76	73	79	76	73	72	
0.8	87	83	79	87	82	79	85	81	79	84	81	78	76	
1	93	88	85	92	88	85	90	87	84	89	86	83	81	
1.25	97	93	90	96	92	89	94	91	88	92	90	87	85	
1.5	101	97	93	99	96	93	97	94	92	95	92	90	88	
2	106	102	100	104	101	99	101	99	97	99	97	95	92	
2.5	109	106	104	107	105	103	104	102	101	101	100	98	95	
3	111	109	107	110	108	106	106	105	103	103	102	101	97	
4	114	112	111	112	110	109	108	107	106	105	104	103	99	
5	115	114	113	113	112	111	109	108	108	106	105	104	100	

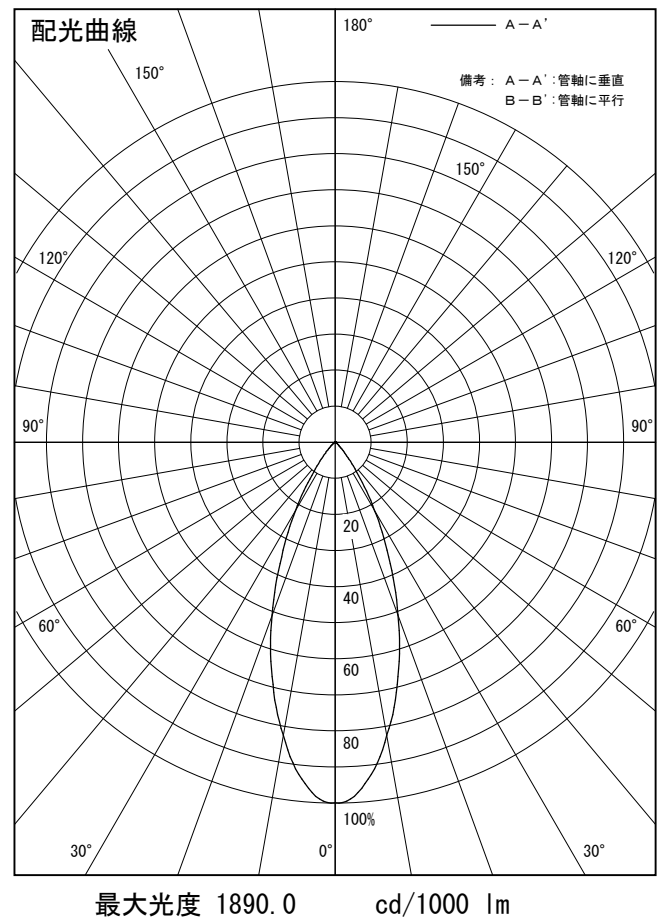
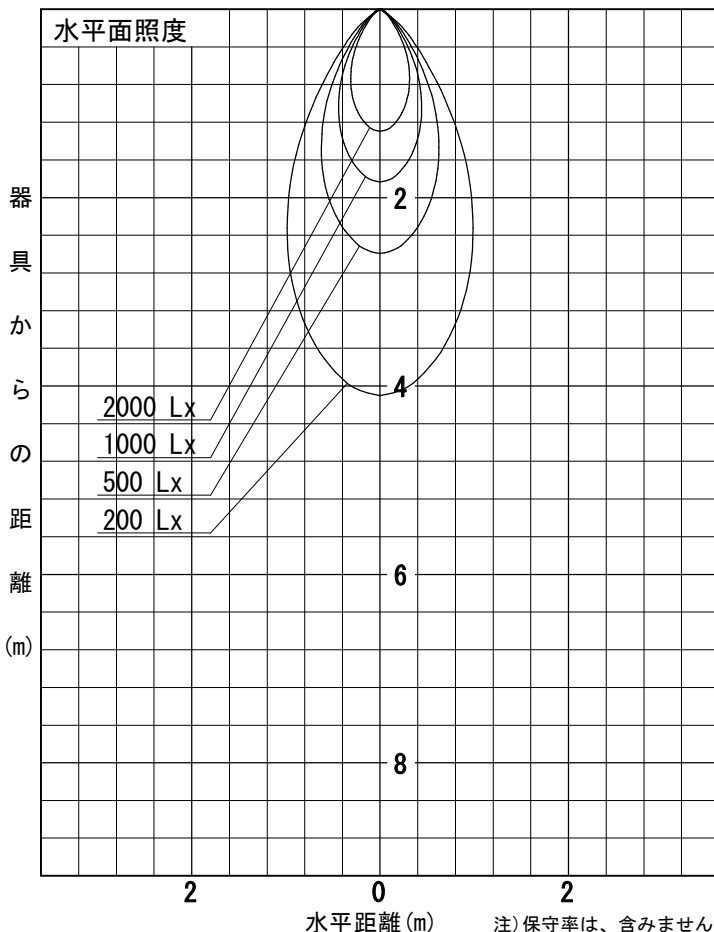

姿図

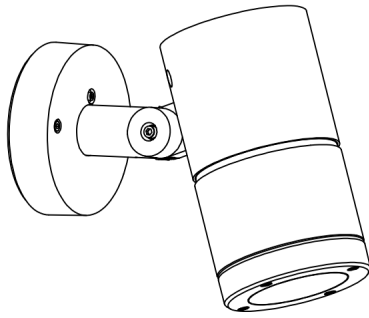

品番	LLS-7103YUM+LZA-90635
光源	LED 38W 3000K
定格光束	1690.0 lm
1/2照度角	30°
ビーム角	34°

器具効率	100.0 %
上方光束	0.0 %
下方光束	100.0 %
器具間隔 最大限 (取付高さH)	A 0.54 H
	B 0.56 H
保守率	良 0.69
	中 0.67
	否 0.63

反射率 (%)	天井	80			70			50			30			0
	壁	50	30	10	50	30	10	50	30	10	50	30	10	0
床	20			20			20			20			0	
室指数	照 明 率 (× 0.01)													
0.6	82	77	74	81	77	74	80	76	74	79	76	73	72	
0.8	88	83	80	87	82	79	86	82	79	84	81	78	77	
1	93	89	85	92	88	85	91	87	84	89	86	84	82	
1.25	98	93	90	97	93	90	94	91	89	93	90	88	85	
1.5	101	97	94	100	96	93	97	94	92	95	93	91	88	
2	106	103	100	104	101	99	102	99	97	99	97	95	92	
2.5	109	106	104	108	105	103	104	103	101	102	100	99	95	
3	112	109	107	110	108	106	107	105	104	103	102	101	97	
4	114	112	111	112	111	109	108	107	106	105	104	103	99	
5	116	114	113	113	112	111	109	109	108	106	105	105	100	

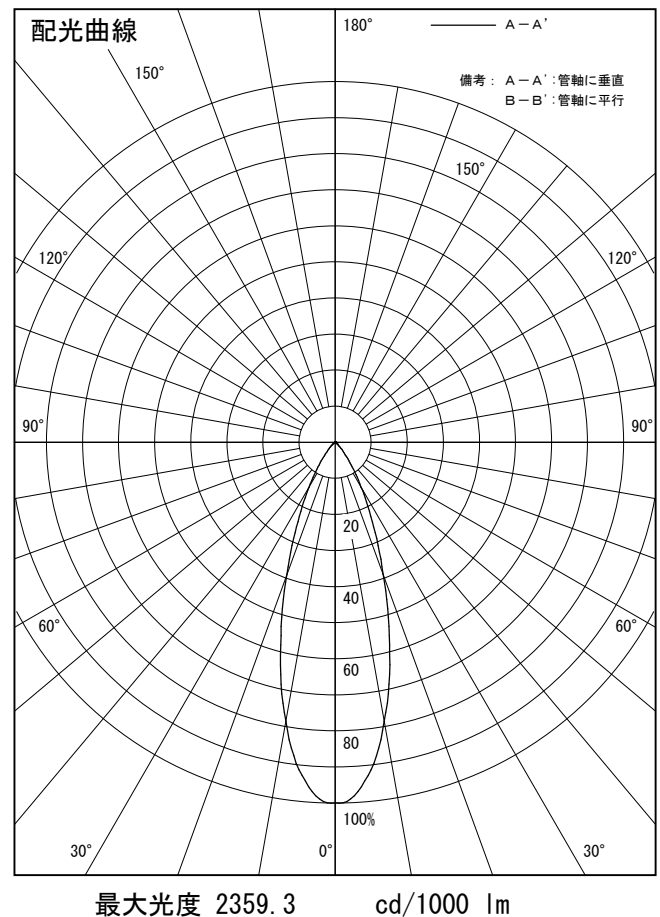
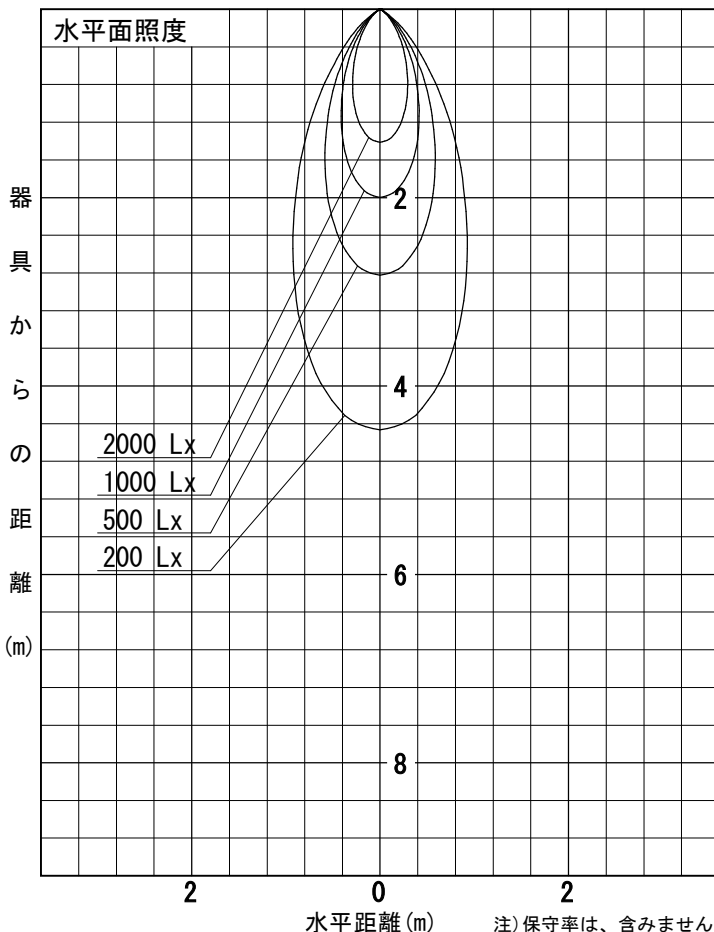

姿図

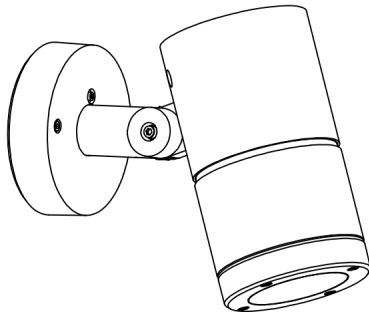

品番	LLS-7103YUM+LZA-90439
光源	LED 38W 3000K
定格光束	2200.0 lm
1/2照度角	18°
ビーム角	18°

器具効率	100.0 %
上方光束	0.0 %
下方光束	100.0 %
器具間隔 最大限 (取付高さH)	A 0.32 H
	B 0.33 H
保守率	良 0.69
	中 0.67
	否 0.63

反射率 (%)	天井			70			50			30			0	
	壁	50	30	10	50	30	10	50	30	10	50	30	10	0
	床	20			20			20			20			0
室指数	照 明 率 (× 0.01)													
0.6	83	79	75	83	78	75	82	78	75	81	77	75	73	
0.8	89	84	81	88	84	80	87	83	80	85	82	79	78	
1	94	90	86	93	89	86	92	88	85	90	87	84	82	
1.25	98	94	91	97	93	90	95	92	89	93	91	88	86	
1.5	102	98	94	100	97	94	98	95	92	96	93	91	89	
2	107	103	100	105	102	100	102	100	98	100	98	96	93	
2.5	110	107	105	108	106	104	105	103	101	102	101	99	96	
3	113	110	108	111	109	107	107	106	104	104	103	102	98	
4	115	113	112	113	112	110	109	108	107	106	105	104	100	
5	117	115	114	115	113	112	111	110	109	107	106	106	101	

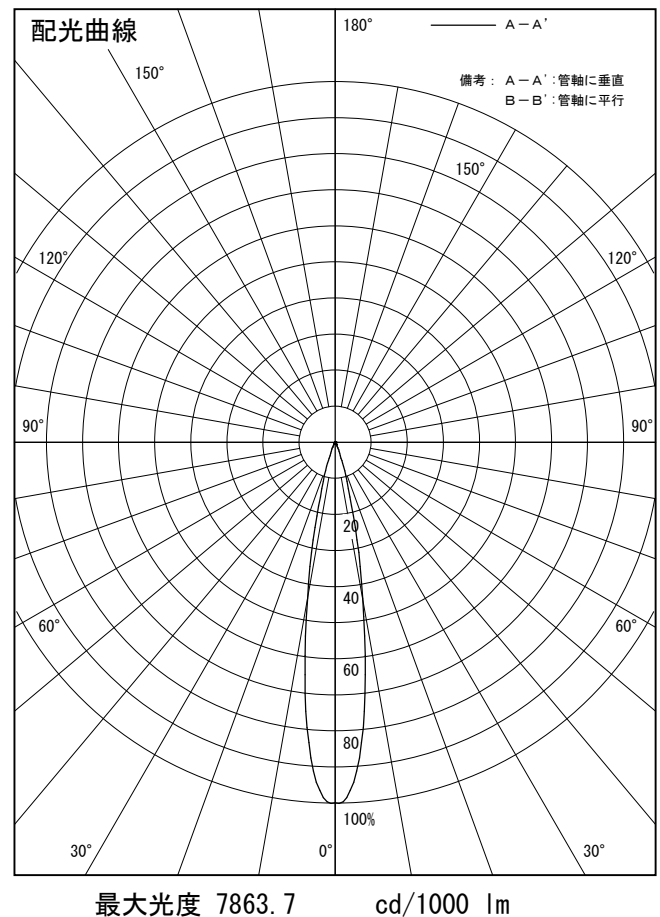
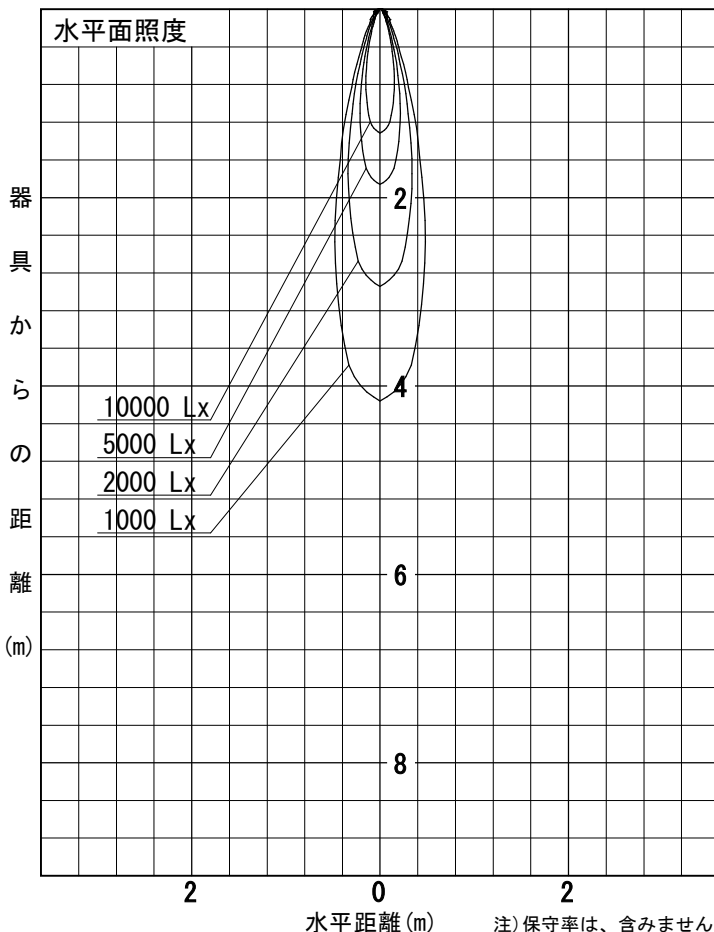

姿図

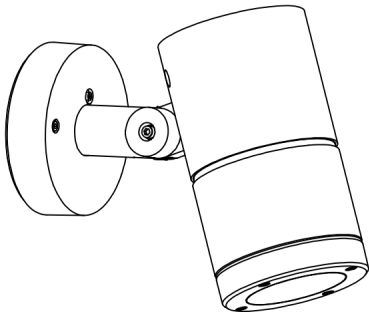

品番	LLS-7103YUM+LZA-90437
光源	LED 38W 3000K
定格光束	2390.0 lm
1/2照度角	18°
ビーム角	18°

器具効率	100.0 %
上方光束	0.0 %
下方光束	100.0 %
器具間隔 最大限 (取付高さH)	A 0.32 H
	B 0.33 H
保守率	良 0.69
	中 0.67
	否 0.63

反射率 (%)	天井	80			70			50			30			0
	壁	50	30	10	50	30	10	50	30	10	50	30	10	0
床	20			20			20			20			0	
室指数	照 明 率 (× 0.01)													
0.6	84	80	77	84	79	76	83	79	76	82	78	76	75	
0.8	90	85	82	89	85	81	88	84	81	86	83	81	79	
1	95	91	87	94	90	87	93	89	86	91	88	85	84	
1.25	99	95	92	98	94	91	96	93	90	94	92	89	87	
1.5	102	98	95	101	98	95	99	96	93	97	94	92	90	
2	107	104	101	106	103	100	103	101	99	101	99	97	94	
2.5	111	108	106	109	107	105	106	104	102	103	102	100	97	
3	113	111	109	111	109	108	108	106	105	105	104	103	99	
4	116	114	112	114	112	111	110	109	108	106	106	105	101	
5	117	116	115	115	114	113	111	110	109	107	107	106	102	

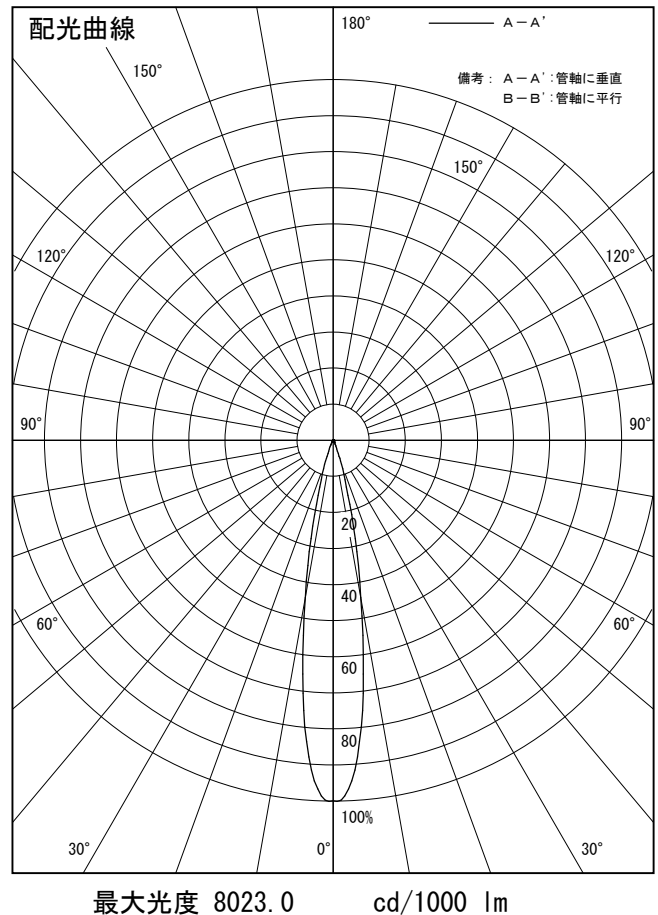
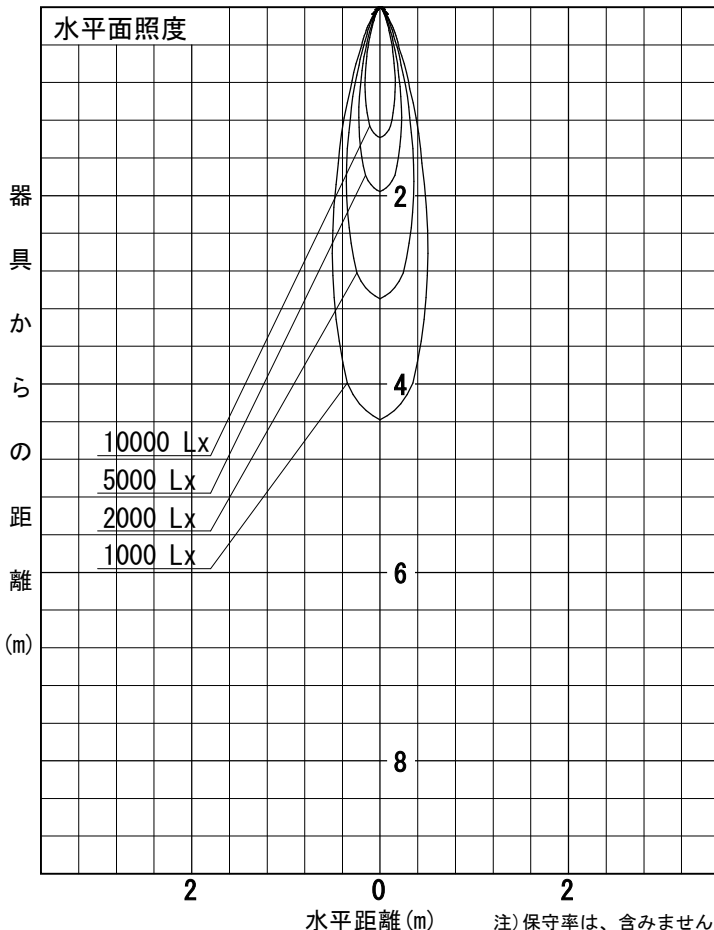

姿図

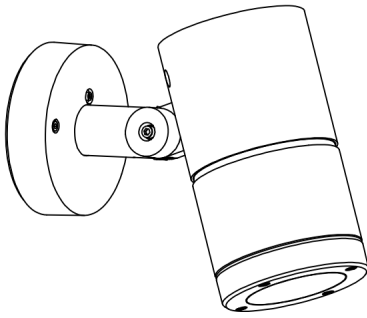

品番	LLS-7103YUM+LZA-90435
光源	LED 38W 3000K
定格光束	2290.0 lm
1/2照度角	A-A' 44° B-B' 18°
ビーム角	A-A' 52° B-B' 18°

器具効率	100.0 %
上方光束	0.0 %
下方光束	100.0 %
器具間隔 最大限 (取付高さH)	A 0.81 H
	B 0.32 H
保守率	良 0.69
	中 0.67
	否 0.63

反射率 (%)	天井			壁			50			30			0		
	80	70	50	50	30	10	50	30	10	50	30	10	50	30	10
床	20	20	20	20	20	20	20	20	20	20	20	20	20	20	20
室指数	照 明 率 (× 0.01)														
0.6	83	79	76	83	79	76	82	78	75	81	78	75	74		
0.8	89	84	81	88	84	81	87	83	80	86	82	80	78		
1	94	90	86	93	89	86	92	88	85	90	87	85	83		
1.25	98	94	91	97	93	90	95	92	89	93	91	88	86		
1.5	101	98	94	100	97	94	98	95	93	96	93	91	89		
2	106	103	100	105	102	100	102	100	98	100	98	96	93		
2.5	110	107	105	108	106	104	105	103	101	102	101	99	96		
3	112	110	108	110	108	107	107	105	104	104	103	102	98		
4	114	113	111	112	111	110	109	108	107	105	105	104	100		
5	116	115	113	114	113	112	110	109	108	106	106	105	101		

A-A'

B-B'

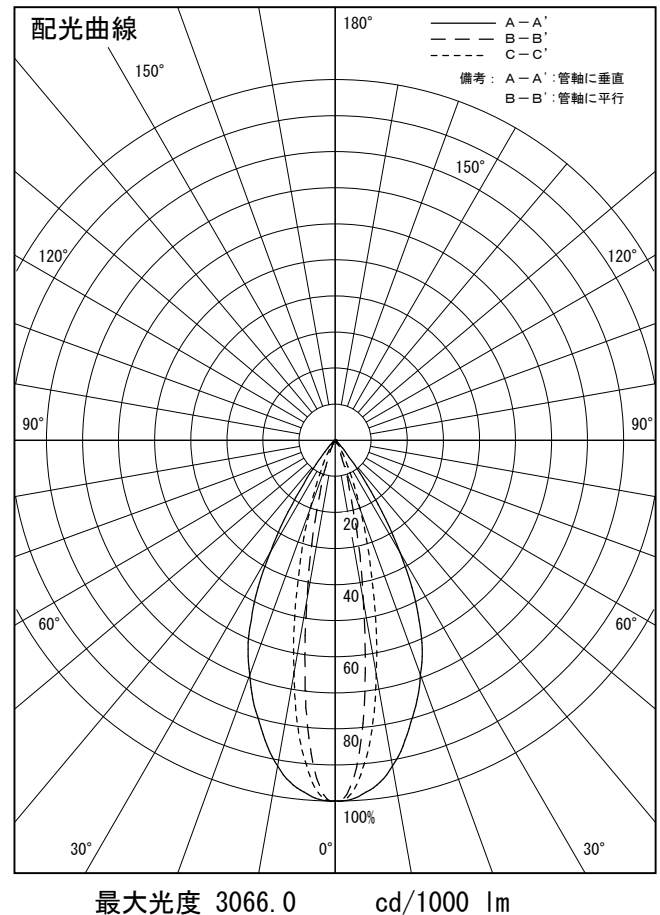
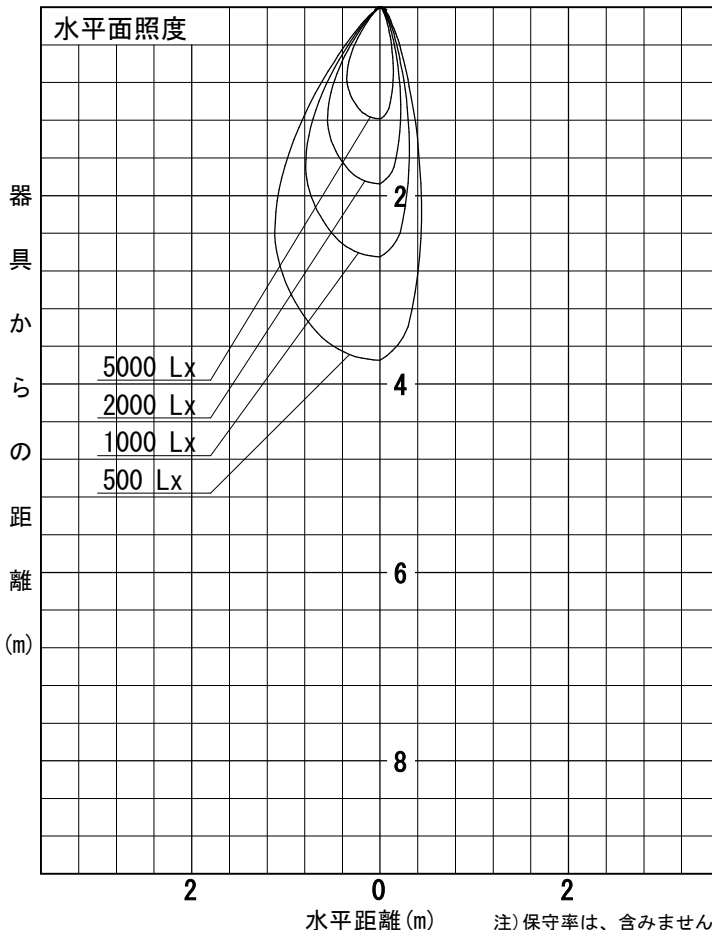

姿図

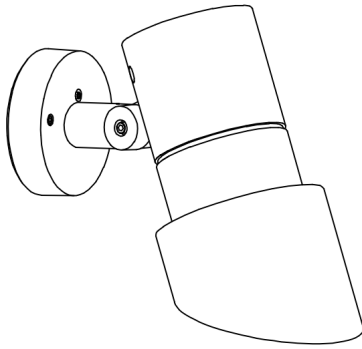

品番	LLS-7103YUM+LLA-7119U
光源	LED 38W 3000K
定格光束	2860.0 lm
1/2照度角	18°
ビーム角	18°

器具効率	100.0 %
上方光束	0.0 %
下方光束	100.0 %
器具間隔 最大限 (取付高さH)	A 0.32 H
	B 0.33 H
保守率	良 0.69
	中 0.67
	否 0.63

反射率 (%)	天井			壁			50			30			0		
	80	70	50	50	30	10	50	30	10	50	30	10	50	30	10
床	20	20	20	20	20	20	20	20	20	20	20	20	20	20	20
室指数	照 明 率 (× 0.01)														
0.6	84	80	77	84	80	77	83	79	77	82	79	76	75		
0.8	90	85	82	89	85	82	88	84	81	87	83	81	79		
1	95	91	88	94	90	87	93	89	86	91	88	86	84		
1.25	99	95	92	98	94	91	96	93	90	94	92	89	87		
1.5	103	99	95	101	98	95	99	96	93	97	94	92	90		
2	107	104	101	106	103	101	103	101	99	101	99	97	94		
2.5	111	108	106	109	107	105	106	104	102	103	102	100	97		
3	113	111	109	111	109	108	108	106	105	105	104	103	99		
4	116	114	112	114	112	111	110	109	108	106	106	105	101		
5	117	116	115	115	114	113	111	110	109	107	107	106	102		

